

Yalehandy Ratchet lever hoist

Capacity 250 - 500 kg

The extreme low tare weight and the very compact design make the hoist easy to use even in confined working conditions. Due to the multitude of application possibilities e.g. in industry, trade and service this ratchet lever hoist is indispensable.



Standard Features

- The enclosed design protects the internal parts from contamination.
- The short handlever is fitted with an ergonomic rubber grip.
- All parts of the disc type load brake are manufactured from high quality materials and are corrosion protected.
- Standard free chaining device to quickly attach the load or to pull the chain through the hoist in both directions.
- Alloyed steel link chain with zinc-plated resp. yellow chromated finish, in accordance with national and international standards and regulations.
- Drop forged suspension and load hooks are made from non-aging, high tensile steel and fitted with robust safety latches.

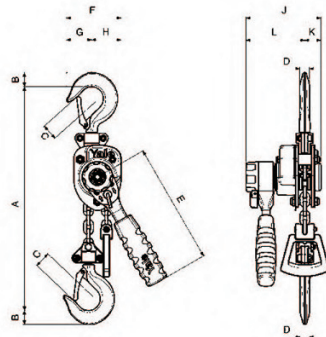

Yalehandy, 250 - 500 kg

Dimensions model Yalehandy

Model	Yalehandy 250	Yalehandy 500
Amin., mm	240	282
B, mm	20	17
C, mm	21	24
D, mm	14	12
E, mm	160	160
F, mm	72	104
G, mm	33	38
H, mm	39	66
J, mm	98	116
K, mm	21	36
L, mm	77	80

Specifications model Yalehandy

Model	Capacity kg	Standard lifting height m	Number of chain falls	Lift with one full lever turn mm	Handle pull at WLL daN	Headroom mm	Weight kg
Yalehandy 250	250	1.5	1	80	25	240	2
Yalehandy 500	500	1.5	1	40	25	282	3